



Dual EZfit Angle Transducer



TRIONIC
vehicle controls

General Features

- Redundant Angle Transducer
- ISO 13849-1 Safety Category 3 PLd Application
- Wide Angle
- Easy Installation (2 screws)
- No moving parts
- Water proof construction IP67

Technical Data

Angle range	$\pm 60^\circ$	
Resolution	Better than 1°	
Response time	100ms max.	
Output Voltage Range	1.0V – 4.0Vdc	2.5V at level
Supply Voltage (reverse protected)	8.5 – 35Volts DC	
Supply Current	20mA max.	
Output Current	2mA	
Operating temperature	-40 – +70 °C	
Storage Temperature	-40 – +85 °C	
Water proof	IP 67	

Dimensions in mm

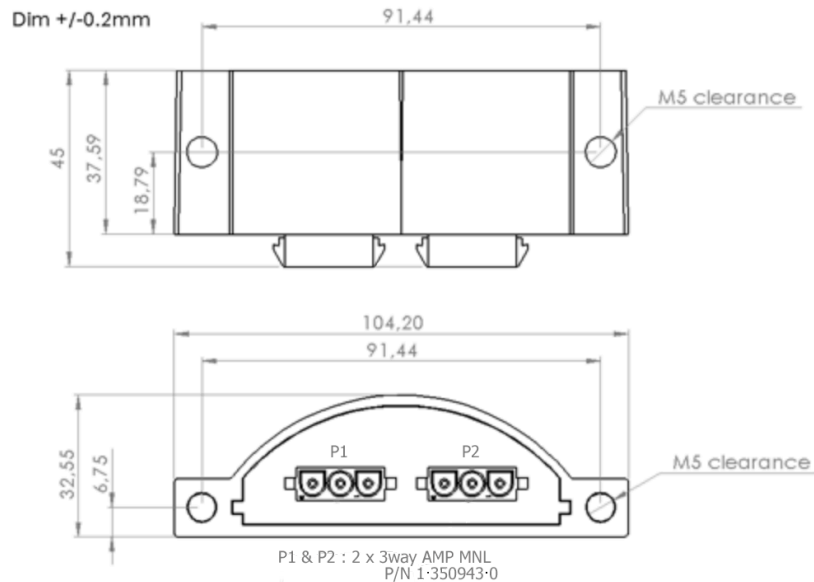

Plug Wiring

Plug 1

Pin 1- B+Ve
Pin 2- Output A
Pin 3- Neg.

Plug 2

Pin 1- B+Ve
Pin 2- Output B
Pin 3- Neg.

Note: Maximum torque to apply to the M5 fixing screws, not to exceed 1Nm.