

## Product Highlights

- Integrated Platform Solution for RT Scissors
- Three digit display shows battery charge status and fault codes to the operator
- Pre-wired – for easy installation
- CANbus enabled
- Compact design
- Customizable

With its compact design, it provides up to 15 momentary switches and 1 optional Finger Joystick for user specific functions and 15 indicator LEDs, as well as an optional Auxiliary connector for additional sensors or switches.



## General Features

- Analog inputs and switch inputs for joystick
- 15 momentary switches
- Three digit display
- Up to 15 LED indicators
- CANbus interface to main valve/motor control module minimizes cable wiring/size
- Optional single axis Finger Joystick
- Integrated Buzzer and optional USB Charger

## Technical Data

<b>Power supply</b>	12/24V	8.5 to 33 VDC	
<b>AUX. Digital Inputs</b>	2	1.25KΩ imp.	
<b>AUX. Analog Inputs</b>	2	0V – 5V	
<b>AUX. Supply output</b>	1	750 mA	<b>Protected</b>
<b>Working temperature</b>	-40 to 60 °C		
<b>Weight</b>	1.4 Kg		
<b>Overall Dimensions</b>	11.8 x 7.6 x 9.3" 298 x 191 x 236 mm		

**Dimensions**

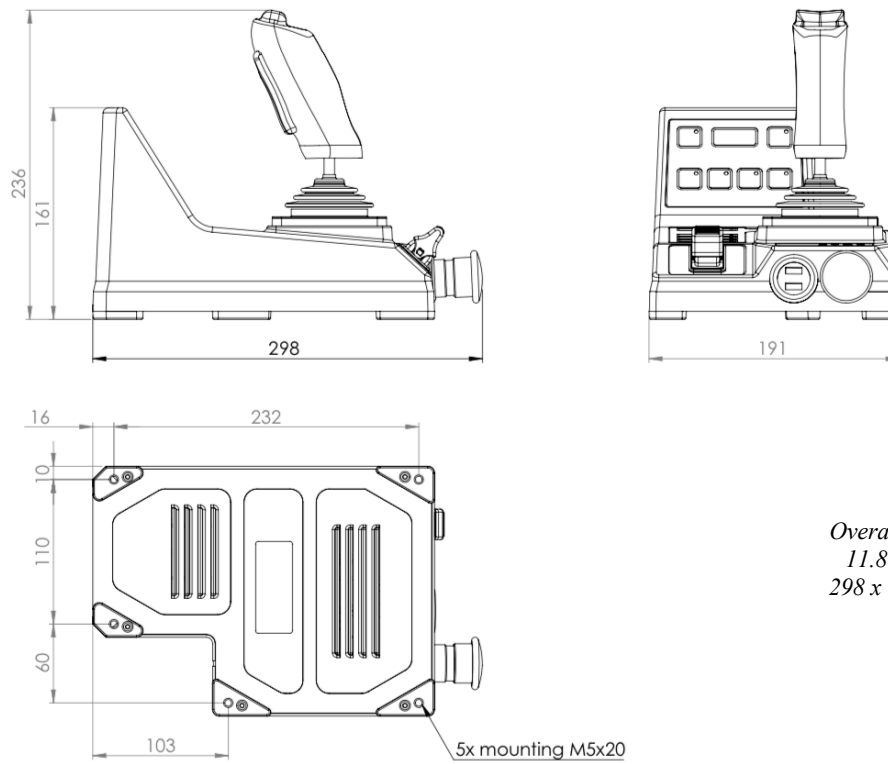

*Overall Dimensions*  
11.8 x 7.6 x 9.3"  
298 x 191 x 236 mm